

欧规横走式三轴/五轴伺服机械手

EURO Cross-walking Three-Axis/Five-Axis Servo Driven Robots

EUW-120/EUW-120s

注塑用机械手 TAKE-OUT ROBOT

EUW-120
EUW-120s

标准功能 STANDARD FUNCTION

装箱动作 (各轴256点)
Packaging motion (Max. 256 points)

自由装箱点 (115点×2处)
Free packaging motion (115points×2stage)

取出侧前进姿势控制
Forward and rotate at removing side

走行途中姿势
Posture control during traverse

落下测下降途中姿势
Posture midway descent at release side

顶针连动
Ejector link

不良品排出回路
Defective product reject circuit

初期不良品排出回路
Initial defective product reject circuit

取出下降待机
Delayed arm descent

胶口途中开放 (去程, 返程)
Midway runner release (Move, Revert)

水口模内开放
Runner release within mold

吸着确认单元 (2回路)
Additional vacuum sensing unit (2 circuit)

横走行待机
Delayed traverse

滑移取出回路
Undercut extract circuit

输送带启动信号
Start signal of conveyor

内部存储记忆 (最大100种类型)
Internal memory (for Max 100 molds)

设定值锁定功能
Lock function of setting value

固定可动切换
Extraction from fixed mold

2国语言切换 (中文, 英文)
Two language exchange (Chinese/English)



型式 MODEL

单位 UNIT EUW-120 EUW-120s

电源 Power Source	V	AC200~220±10% 50/60Hz	
最大消费电力 Max Power Consumption	KW	2.35	3.5
使用气压 Air Pressure	Mpa	0.5~0.7	
空气消费量 Air Consumption	NI/cycle	9.7	
驱动方式 Drive System	---	伺服马达 / AC Servo Motor	
姿势 (气缸) Posture (Air Cylinder)	---	90°固定 / 90°Fixed	
■ 气缸推力 (气压0.49MPa时) Air Cylinder Driving Force (Air Pressure at 0.49MPa)			
最大可搬重量 Max.Load	Kg	8【含夹具重量 / Incl Chuck Weight】	
姿势力矩 Posture Torque	N·m	25.8	
■ 行程 Stroke			
主臂上下 Main-arm Vertical	mm	1200/1400	1200/1400
副臂上下 Sub-arm Vertical	mm	---	1250/1450
前后(主臂,副臂) Crosswise (M,S)	mm	主臂/M 280~1200	副臂/S 515~1200 265~950
走行 Traverse	mm	1800	
■ 本体重量 Net Weight			
本体 Main Body	Kg	567	613
操作盒 Pendant	Kg	1.6	

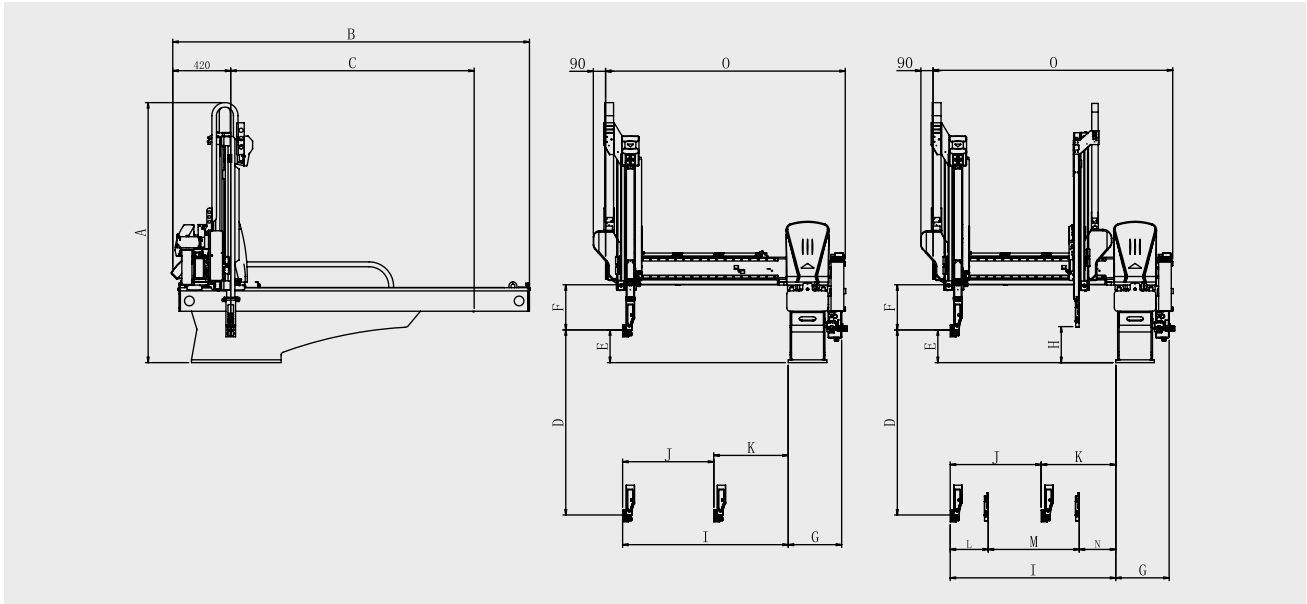

外形尺寸 OUTER DIMENSIONS

EUW-120 EUW-120s

选项功能 OPTION FUNCTION

A	总高 Overall height	1890 (1950) mm	
B	总长 Overall length	2600 mm	
C	走行行程 Traverse stroke	1800 mm	
D	主臂上下行程 Main-arm vertical stroke	1200 (1400) mm	
E	主臂上下待机 Main-arm vertical standby	230 mm	
F	夹具安装有效空间 Bottom of crosswise to chuck mount position	325 mm	
G	底座里侧面-箱体末端 Base side face-Box end	405 mm	
H	副臂上下待机 Sub-arm Vertical standby	---	280 mm
I	主臂前进最大值 Main-arm reach max	1200mm	
J	主臂前进最大行程 Main-arm crosswise stroke max	800 mm	685mm
K	主臂前后待机最小值 Main-arm crosswise standby min	280 mm	515 mm
L	主副臂接近最小值 Main/Sub-arm proximity min	---	250mm
M	副臂前进最大行程 Sub-arm crosswise stroke max	---	685mm
N	副臂前后待机最小值 Sub-arm crosswise standby min	---	265 mm
O	前后臂末端-箱体末端 Crosswise arm end-Box end	1740 mm	

- ◆ 夹具内剪刀回路
Air nipper in chuck circuit
- ◆ NT剪切·可动侧
NT gate cutting on crossmember of moving
- ◆ 吸着确认4回路
Additional vacuum sensing unit (4 circuits)
- ◆ 制品夹取4回路
Product gripping 4 circuits
- ◆ 上升途中闭模
Mold close during ascend
- ◆ 回转单元
Rotation unit
- ◆ 顶针后退连动
Ejector return link
- ◆ 欧规12
EUROMAP12
- ◆ 欧规67
EUROMAP 67

- 当尺寸C是1200mm时，尺寸B为1890mm
- when dimension C is 1200mm , B is 1890mm

- 当尺寸C是1400mm时，尺寸B为1950mm
- when dimension C is 1400mm , B is 1950mm

有关产品性质和适用范围的说明并不保证产品属性，仅作可供了解的信息。我们的供货范围及提供的服务完全以合同条款为准绳。技术数据和插图仅作为供货参考。保留更改权利。

Feature and scope of the product does not guarantee the product attributes, only for reference. Our scope of delivery and services provided are based solely on the terms of delivery and services provided are based solely on the terms of the contract. Technical data and illustration are only for reference. We reserve the rights of changing.

TSD-2021-12

广东拓斯达科技股份有限公司

GUANGDONG TOPSTAR TECHNOLOGY CO.,LTD.

地址：广东省东莞市大岭山镇大塘朗创新路2号

ADD : No.2 Chuangxin Road, Datanglang, Dalingshan Town, Dongguan City, Guangdong Province.

电话/TEL: 0769-8305 0999 传真/FAX: 0769-8584 5562

全国统一客服热线 Domestic Service Hotline **400-096-8005**

